



Agilent Positive Pressure Manifold 48 and 96 Processors

User Manual

Notices

© Agilent Technologies, Inc. 2017

No part of this manual may be reproduced in any form or by any means (including electronic storage and retrieval or translation into a foreign language) without prior agreement and written consent from Agilent Technologies, Inc. as governed by United States and international copyright laws.

Manual Part Number

G6695-90001

Edition

First edition, August 2017

Printed in USA

Agilent Technologies, Inc.
5301 Stevens Creek Boulevard
Santa Clara, CA 95051-7201 USA

The contents are the original instructions supplied by Agilent Technologies.

Warranty

The material contained in this document is provided “as is,” and is subject to being changed, without notice, in future editions. Further, to the maximum extent permitted by applicable law, Agilent disclaims all warranties, either express or implied, with regard to this manual and any information contained herein, including but not limited to the implied warranties of merchantability and fitness for a particular purpose. Agilent shall not be liable for errors or for incidental or consequential damages in connection with the furnishing, use, or performance of this document or of any information contained herein. Should Agilent and the user have a separate written agreement with warranty terms covering the material in this document that conflict with these terms, the warranty terms in the separate agreement shall control.

Safety Notices

CAUTION

A **CAUTION** notice denotes a hazard. It calls attention to an operating procedure, practice, or the like that, if not correctly performed or adhered to, could result in damage to the product or loss of important data. Do not proceed beyond a **CAUTION** notice until the indicated conditions are fully understood and met.

WARNING

A **WARNING** notice denotes a hazard. It calls attention to an operating procedure, practice, or the like that, if not correctly performed or adhered to, could result in personal injury or death. Do not proceed beyond a **WARNING** notice until the indicated conditions are fully understood and met.

Contents

Safety and Regulatory Information

- Intended Use 6
- Safety and Regulatory Certifications 7

Introduction

- Product Description 10
- Agilent Positive Pressure Manifold 48 Processor 11
- Agilent Positive Pressure Manifold 96 Processor 14
- Processor Components 15
- Maintaining Manifold Pressure 16
- Flow Control 18

Processor Setup

- Site Requirements 20
- Parts and Accessories 21
- Installation 23

Operation

- Processor Preparation 26
- Sample Processing 26

Maintenance

- Bleed off the Processor 30
- Tubing Replacement 31
- Sealing Gasket Replacement 32

Reference Procedures

- Using Your Agilent PPM-48 Processor 34
- Using Your Agilent PPM-96 Processor 35

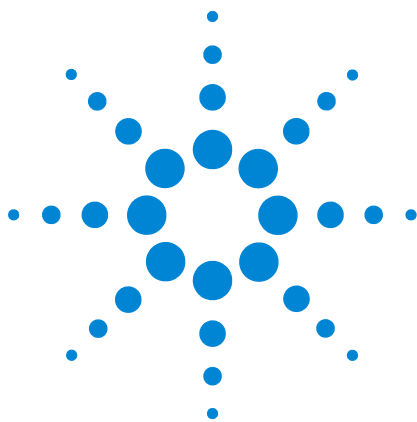

1 Safety and Regulatory Information

Intended Use 6

Safety and Regulatory Certifications 7

Intended Use

The Agilent positive pressure manifold 48 and 96 processors are used to perform manual sample processing of analytes from various sample types as a stand-alone, independent module for sample preparation. The processor is intended to be used in a professional laboratory setting to perform various manual sample preparation techniques, such as solid phase extraction, using positive pressure application to 1, 3, and 6 mL cartridges and 96-well format filter/extraction plates to prepare samples for downstream testing.

Safety and Regulatory Certifications

Declaration of Conformance

Manufacturer's Name:

Agilent Technologies, Inc.

Manufacturer's Address:

5301 Stevens Creek Boulevard
Santa Clara, CA 95051-7201 USA

Declares under sole responsibility that the product as originally delivered

Product Name & Function:

Positive Pressure Manifold Processors

Model & Part Numbers:

5191-4101; 5191-4116

Product Options:

Positive Pressure Manifold 48 Processor
Positive Pressure Manifold 96 Processor

complies with the essential requirements of the following applicable European Directives, and carries the CE marking accordingly:

Machinery Directive 2006/42/EC

Contact established in the Community authorized to compile the technical file or the relevant technical documents:

Agilent Technologies Deutschland GmbH
Hewlett-Packard Strasse 8, 76337 Waldbronn
Germany

Important Safety Warnings

There are several important safety notices that you should always keep in mind when using Agilent positive pressure manifold 48 and 96 processors.

WARNING

When using this product, always wear appropriate Personal Protective Equipment (PPE) to protect the user from the hazards of the sample being processed, including but not limited to, safety glasses or goggles, lab coat, and gloves.

WARNING

Sample and waste materials from use of processor should be disposed of with appropriate waste handling procedures dictated by the hazards of the materials.

Symbols

Warnings in the manual or on the instrument must be observed during all phases of operation, service, and repair of this instrument. Failure to comply with these precautions violates safety standards of design and the intended use of the instrument. Agilent Technologies assumes no liability for the customer's failure to comply with these requirements.

See accompanying instructions for more information.

Indicates a pinching or crushing hazard.





2 Introduction

Product Description	10
Agilent Positive Pressure Manifold 48 Processor	11
Agilent Positive Pressure Manifold 96 Processor	14
Processor Components	15
Maintaining Manifold Pressure	16
Flow Control	18

Product Description

For sample preparation techniques such as solid phase extraction (SPE), supported liquid extraction (SLE), and filtration (protein precipitation), Agilent positive pressure manifold (PPM) 48 and 96 processors offer:

- **Uniform flow:** Restricted-flow ports ensure consistent gas flow across the manifold, regardless of cartridge or well contents.
- **No more troublesome stopcocks:** The restricted-flow ports eliminate the need for stopcocks, which must be individually and manually controlled.
- **Easy alignment:** The self-adjusting manifold correctly aligns cartridges, test tubes, autosampler vials, and 96-well plates without the need for additional spacers.
- **Speed and cost efficiency:** The 48-cartridge capacity lets you process more samples at once.
- **Time and resource savings:** The autosampler vial collection rack for the PPM-48 allows you to skip the final transfer step.
- **Greater flexibility:** Forced gas supplies a wide range of pressures for processing viscous samples.

Agilent Positive Pressure Manifold 48 Processor

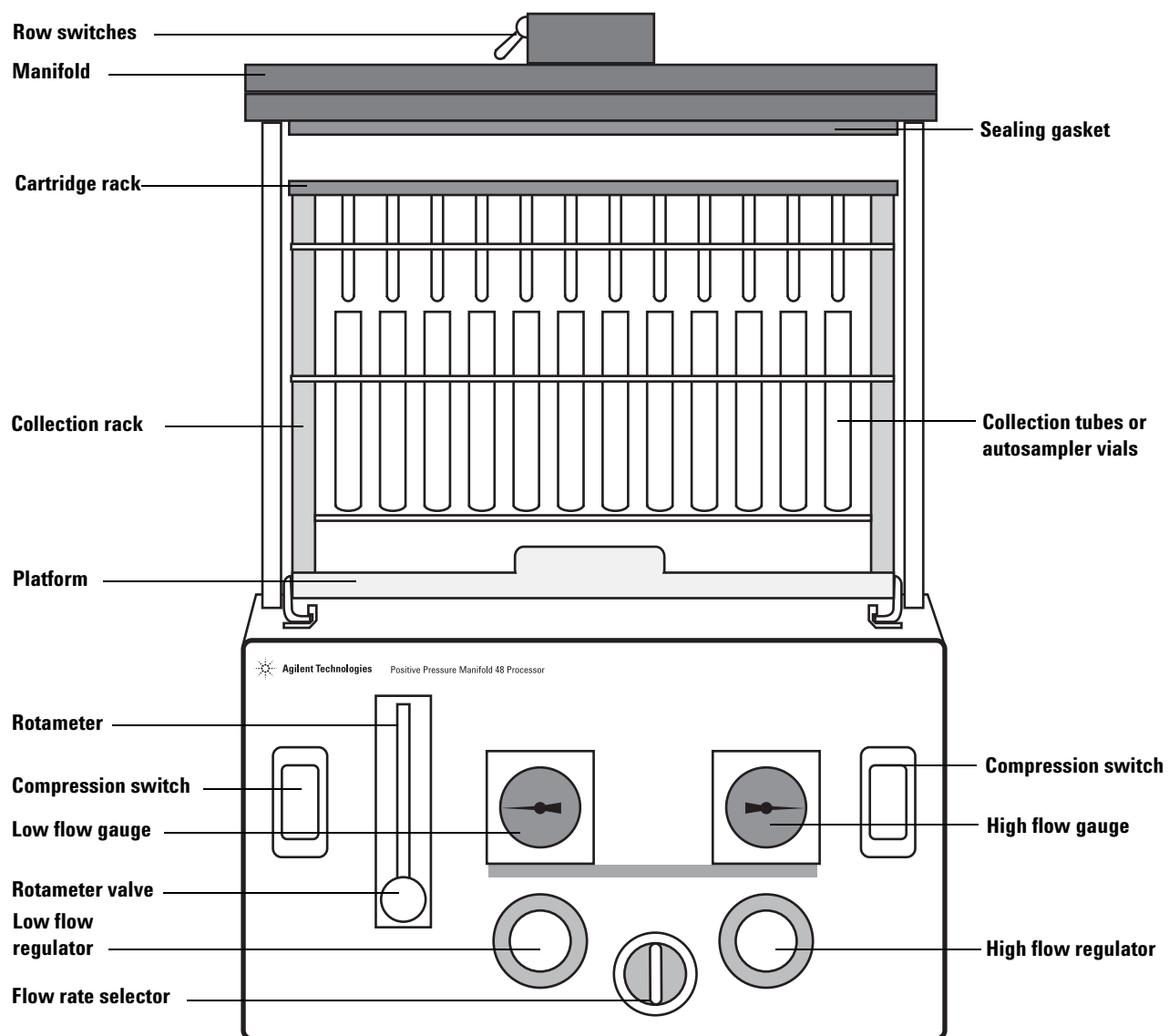

Figure 1 Agilent positive pressure manifold 48 processor

The Agilent positive pressure manifold 48 processor (PPM-48) (see [Figure 1](#)) allows batch processing of material through up to 48 cartridges.

A unique feature of the PPM-48 is that each of the four rows is controlled by a switch, located on top of the manifold. These switches may be used to turn off gas flow to individual rows of 12, thus saving gas when those rows are not in use. When the PPM-48 is set to **Low Flow**, the rotameter only shows the total flow through the turned on rows.

Several 48-position sample collection racks are available to use with the processor. The sample collection racks can accommodate autosampler vials and many common collection tube sizes:

- 10 × 75 mm
- 12 × 75 mm
- 13 × 100 mm
- 16 × 100 mm

Contact your local Agilent representative for further details.

The PPM-48 also accommodates multiple types of cartridge racks, for multiple sizes of cartridges, as outlined in [Table 1](#).

Table 1 Cartridge rack sizes and capacities

Cartridge size	Cartridge rack capacity
1 mL	up to 48 cartridges
3 mL	up to 48 cartridges
6 mL	up to 48 tabless cartridges or 24 tabbed cartridges

If 24 tabbed cartridges are being used in a 6 mL cartridge rack, the cartridges must be oriented in alternating rows (A and C, or B and D) so that the tabs on each cartridge are all vertical and parallel with each other (see [Figure 2](#) on page 13). Incorrect cartridge orientation prevents the cartridges from resting level in the cartridge rack, thus impeding proper gas flow to the cartridges. Gas can be saved by turning off the empty rows.



Figure 2 6 mL tabbed cartridge orientations

The sample collection rack is keyed to the platform, and the cartridge racks are keyed to the collection racks, so that sample position is preserved throughout the process. If the material exiting the cartridges is to be disposed, a waste collection rack with a removable waste bin is available to use, instead of a sample collection rack.

Agilent Positive Pressure Manifold 96 Processor

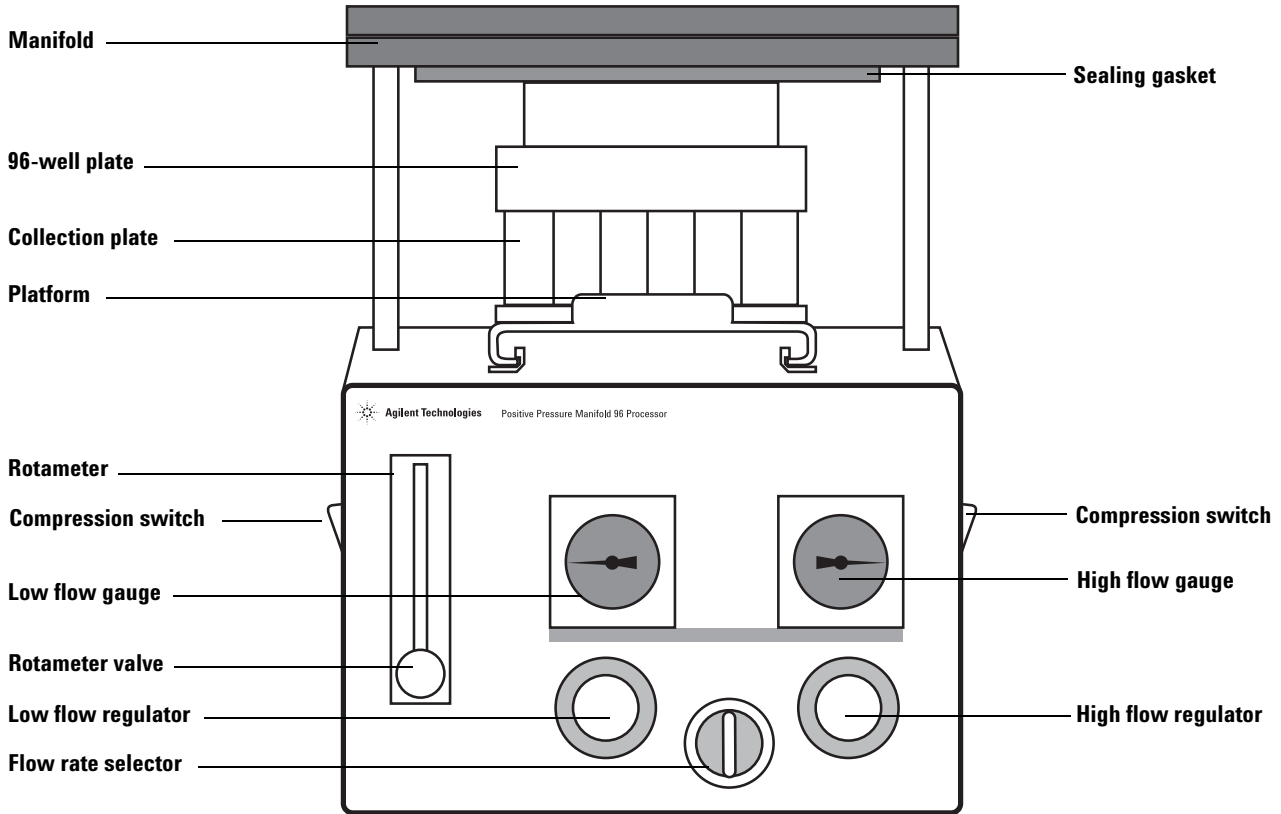

Figure 3 Agilent positive pressure manifold 96 processor

One of the benefits of the Agilent positive pressure manifold 96 processor (PPM-96) is the ability to use the processor for both 96-well plates and 1 mL cartridges. Tabless 1 mL cartridges may be assembled in a cartridge holder (p/n 5191-4119).

Alternatively, an Agilent VersaPlate base plate (p/n 75400000) can be used with VersaPlate tubes. Both of these options provide the flexibility to create your own customized 96-well plates, expediting method development. This eliminates the need to run multiple 96-well plates with different sorbents.

The PPM-96 is designed to accommodate 1 mL or 2 mL 96-well plates, in both round-well and square-well formats.

Either a sample collection plate, or a waste collection plate may be used under the 96-well plate. If a 1 mL round-well plate is being used with the waste collection plate, a plate holder (p/n 5191-4120) may be used on top of the waste collection plate to stabilize the 96-well plate during processing. The rows are labeled A–H, and the columns are labeled 1–12 on the 96-well plate, tabless cartridge holder, sample collection plate, and VersaPlate to aid in preserving sample position.

Processor Components

Table 2 provides a list of the components of the PPM-48 and PPM-96 processors, and a brief description of their functions.

Table 2 Processor components

Component	Function
Flow rate selector	Controls the operating mode (Off , Low Flow , High Flow).
Compression switches	Lowers and raises the manifold.
Rotameter	Allows for fine tune flow control in Low Flow mode.
Row toggle switches (PPM-48 only)	Controls the flow to each row of cartridges.
Flow regulators	Controls and sets the pressure for both the Low Flow (left knob) and High Flow (right knob) operating modes.
Platform	Moves the cartridge stack, or 96-well plate stack, forwards and backwards on the processor. Aligns the manifold with the rack or plate stack.
Low Flow gauge	Displays the Low Flow pressure.
High Flow gauge	Displays the High Flow pressure.
Manifold	Compresses to achieve a seal. Delivers gas through flow restricted ports to cartridges or a 96-well plate.
Sealing gasket	Creates a seal between the manifold and either a cartridge rack or a 96-well plate.

Maintaining Manifold Pressure

The cartridges' sorbent beds restrict the sample flow, allowing the flow to increase only as increased pressure is applied (see [Figure 4](#)).

Each of the holes in the manifold has a small gas flow restrictor installed. The restrictors allow the manifold to maintain pressure, even when the cartridge rack has empty positions, or as the cartridges elute. As the cartridges start to empty, the restrictors help maintain pressure in the cartridges that still contain fluid, thus allowing processing to continue (see [Figure 5](#) on page 17).

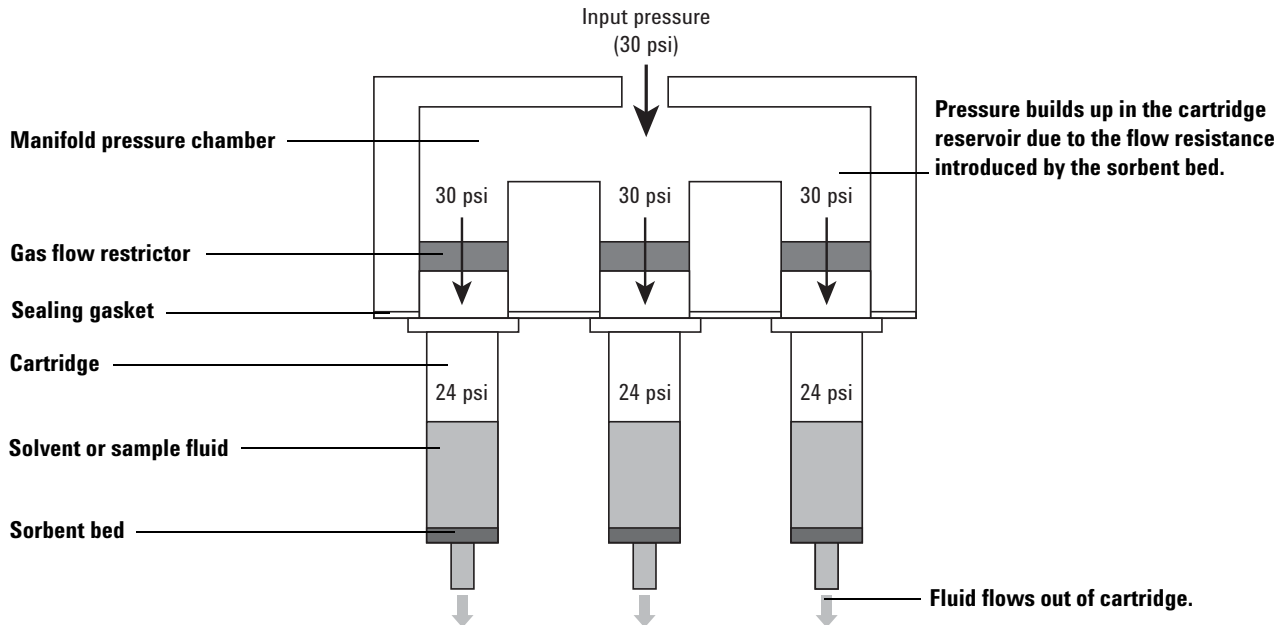

Figure 4 Manifold restrictor design with full cartridges

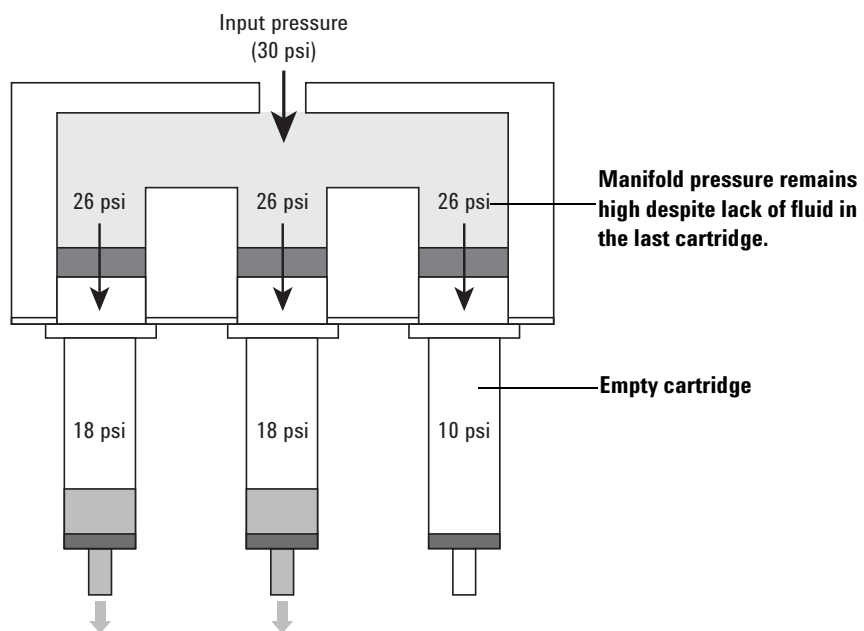

Figure 5 Manifold restrictor design with empty cartridge

Flow Control

When the flow rate selector is set to **Off**, no gas will flow to the manifold.

The processors each have two gas delivery settings to pressurize the cartridges or 96-well plates.

The **Low Flow** setting provides a slow, precise gas flow to the manifold. This setting creates a gas flow path through the low flow regulator and the rotameter before entering the manifold. The low flow regulator can be used to set pressures from 0 to 15 psi, and the rotameter can be used to limit flow rates from 0 to 2.5 SCFH.

CAUTION

To avoid damage to the processor, never shut off the rotameter. Only use the flow rate selector to turn the gas flow on or off.

The **High Flow** setting provides an increased gas flow to the manifold. This setting creates a gas flow path through the high flow regulator directly to the manifold. The high flow regulator can be used to set pressures from 0-100 psi. This setting is commonly used for processing viscous or high particulate samples, or for drying the cartridges during the sample processing procedure.

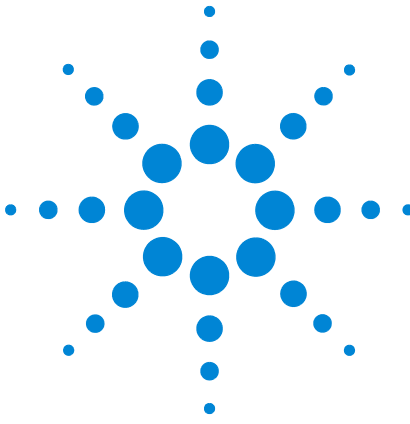

3 Processor Setup

Site Requirements 20

Parts and Accessories 21

Installation 23



Site Requirements

Ensure your workstation is able to accommodate the specifications of your processor, as shown in [Table 3](#).

Table 3 Processor specifications

Processor	Size	Weight	Operating temperature	Maximum relative humidity
PPM-48	33.5 × 30.5 × 39 cm (13.2 × 12 × 15.4 inches)	13.4 kg (29.6 lbs)	5 °C to 40 °C (41 °F to 104 °F)	80%
PPM-96	27.1 × 30.5 × 32.5 cm (10.7 × 12.0 × 12.8 inches)	11.0 kg (24.2 lbs)	5 °C to 40 °C (41 °F to 104 °F)	80%

CAUTION

The processors are not supplied with a filter for the source gas input. Use a clean, oil-free gas source to help prevent sample contamination.

If you are using a filter with your processor, ensure your workstation can accommodate both the processor and filter. Agilent recommends using a BHT-4 (1/4 inch fittings) or BHT-2 (1/8 inch fittings) filter to help prevent sample contamination. The filter must be positioned vertically, and is not self-supporting.

The processors are designed to be operated only indoors.

WARNING

Always perform sample processing in an area with appropriate environmental controls (ventilation, additional enclosures) dictated by the hazards of the samples being processed.

Agilent recommends using compressed nitrogen as the gas supply for your processor. If compressed nitrogen is not available, the processors can operate using high purity filtered instrument air. [Table 4](#) shows the optimum, minimum, and maximum input pressures for your processor.

Table 4 Processor input pressures

Optimum source pressure	Minimum pressure	Maximum pressure
80 psig	60 psig	100 psig

Parts and Accessories

[Table 5](#) and [Table 6](#) display the parts included with the PPM-48 (p/n 5191-4101) and PPM-96 (p/n 5191-4116) respectively. [Table 7](#) and [Table 8](#) on page 22 show additional accessories that may be ordered individually.

Table 5 Agilent positive pressure manifold 48 processor included parts

Part	Part number
Waste rack with three waste bins	5191-4112
Installation kit	5191-4114
User Manual	G6695-90001

Table 6 Agilent positive pressure manifold 96 processor included parts

Part	Part number
Single well waste plate	5191-4121
Holder for plates	5191-4120
Installation kit	5191-4114
User Manual	G6695-90001

The installation kits provided with the PPM-48 and PPM-96 are identical, and include the following:

- Polyethylene tubing (6', 1/8" i.d., 1/4" o.d.)
- 1/8" NPT connectors
- 1/4" NPT connectors

[Table 7](#) lists the accessories that may be used with the PPM-48 processor.

Table 7 Agilent positive pressure manifold 48 processor accessories

	Description	Part number
Cartridge racks	1 mL cartridge rack	5191-4102
	3 mL cartridge rack	5191-4103
	6 mL cartridge rack	5191-4104

Table 7 Agilent positive pressure manifold 48 processor accessories (continued)

	Description	Part number
Collection racks	10 × 75 mm tubes	5191-4105
	12 × 75 mm tubes	5191-4106
	13 × 100 mm tubes	5191-4107
	16 × 100 mm tubes	5191-4108
	12 × 32 mm autosampler vials	5191-4109
Additional accessories	Sealing gasket for PPM-48	5191-4110
	Waste bin for PPM-48, 3/pk	5191-4113
Gas traps	Big Hydrocarbon Trap (1/4 inch fittings)	BHT-4
	Big Hydrocarbon Trap (1/8 inch fittings)	BHT-2

[Table 8](#) lists the accessories that may be used with the PPM-96 processor.

Table 8 Agilent positive pressure manifold 96 processor accessories

	Description	Part number
Collection plates and sealing mats	Square-well collection plate, 350 µL, 50/pk	5133007
	Square-well collection plate, 1 mL, 50/pk	5133008
	Square-well collection plate, 2 mL, 50/pk	5133009
	Square 96-well sealing mat, 50/pk	5133005
	Captiva 96-deep well collection plate, 1 mL, 10/pk	A696001000
	Captiva pierceable 96-deep well collection plate cover, 10/pk	A8961007
Additional accessories	Sealing gasket for PPM-96	5191-4117
	1 mL tabless cartridge holder for PPM-96	5191-4119
	Single well waste plate	5191-4121
Gas traps	Big Hydrocarbon Trap (1/4 inch fittings)	BHT-4
	Big Hydrocarbon Trap (1/8 inch fittings)	BHT-2

Installation

- 1 Set the processor on your workbench, near your gas source. See “[Site Requirements](#)” on page 20 for information about selecting an appropriate source.

WARNING

When installing a new processor, only use the tubing provided in the installation kit (p/n 5191-4114).

- 2 Ensure the flow rate selector is turned to **Off**, and that your gas source is off.
- 3 Cut the provided tubing to the desired lengths. If the cut is not clean and even, repeat (see [Figure 6](#)).



Figure 6 Properly cut tubing

- 4 If you are using a filter with your processor, use the tubing provided to attach the filter to your gas source. Agilent recommends using a BHT-4 (1/4 inch fittings) or BHT-2 (1/8 inch fittings) filter to help prevent sample contamination.
- 5 Connect the filter to the processor gas inlet, so that gas flows through the filter prior to entering the processor. Push the tubing into the push-to-connect fitting until it is fully seated in the fitting. See [Figure 7](#) on page 24 and [Figure 8](#) on page 24 for diagrams showing proper tubing installation. If you are not using a filter, use the tubing provided to connect your gas source directly to your processor’s gas inlet.

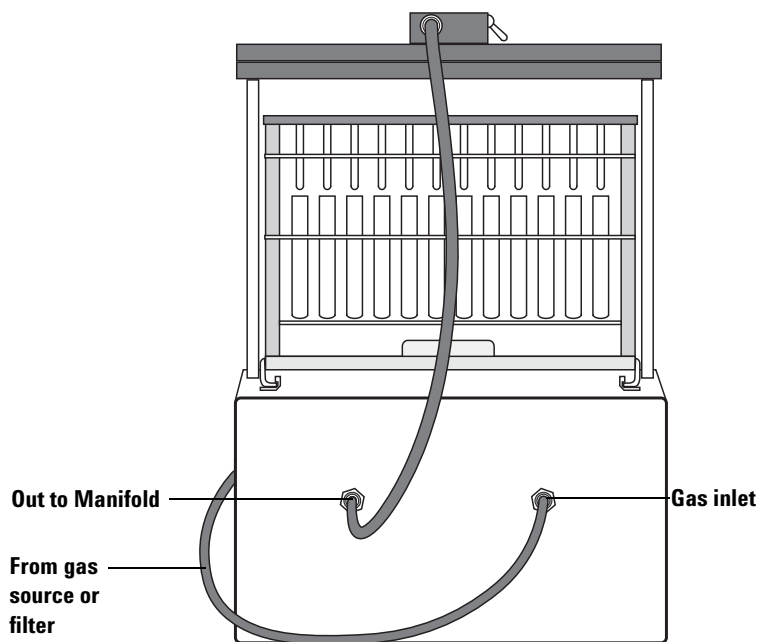

Figure 7 Agilent positive pressure manifold 48 processor gas connections

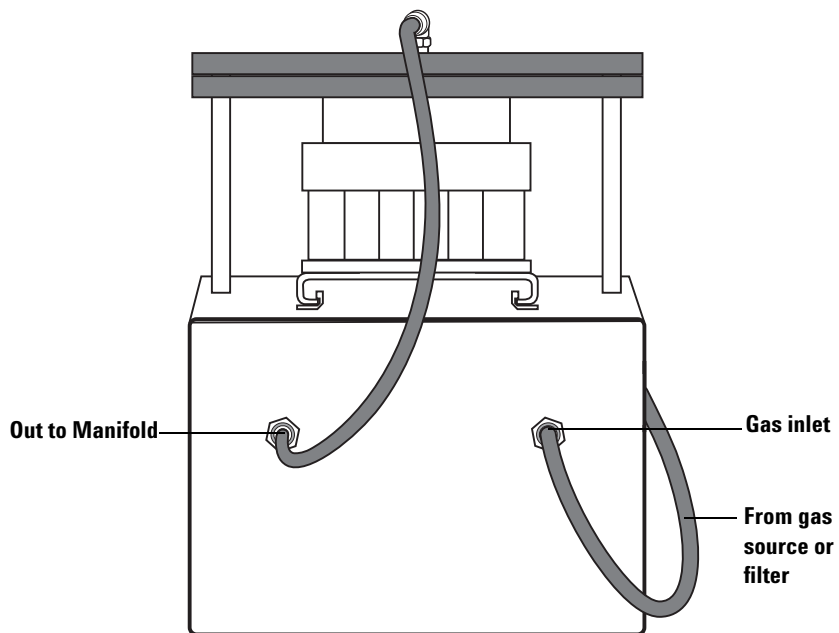
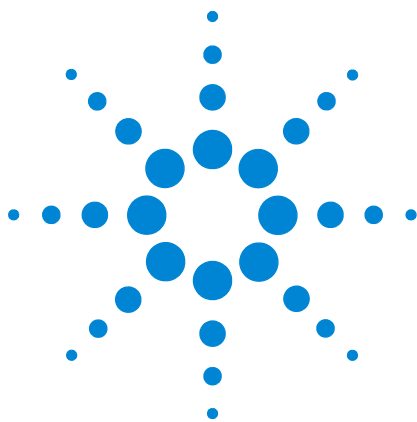

Figure 8 Agilent positive pressure manifold 96 processor gas connections



4 Operation

Processor Preparation 26

Sample Processing 26

Processor Preparation

- 1 Ensure that the processor is connected to a gas supply, and that the flow rate selector is turned to **Off**. See [“Site Requirements”](#) on page 20 and [“Installation”](#) on page 23 for more information.
- 2 Turn on your gas supply.

Sample Processing

For a summary of this procedure that may be kept near your processor and referenced, see [“Using Your Agilent PPM-48 Processor”](#) on page 34 and [“Using Your Agilent PPM-96 Processor”](#) on page 35.

For specific workflow guidelines and sample protocols, refer to *A Technical Guide to Agilent Positive Pressure Manifold 48 and 96 Processors* (5991-8151EN).

- 1 Slide the platform out from under the manifold.
- 2 Assemble the stack (see [Figure 9](#) and [Figure 10](#)).

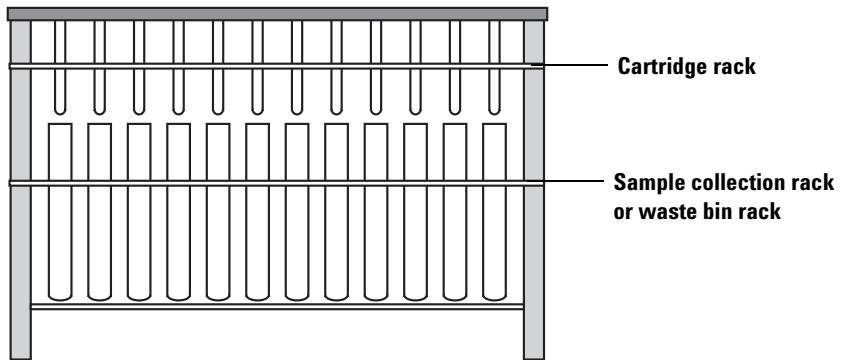

Figure 9 Agilent positive pressure manifold 48 processor stack

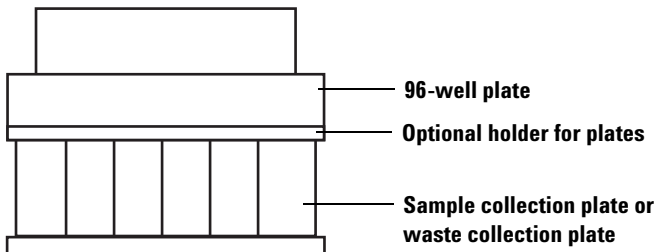

Figure 10 Agilent positive pressure manifold 96 processor stack

- 3 Place the stack on top of the platform. When positioned correctly, the stack should sit level on the platform.

- 4 If you are using a PPM-48, flip the row switches on top of the manifold down to open the desired row valves.
- 5 Turn the flow rate selector from **Off** to **Low Flow**, to release any excess manifold pressure.
- 6 Adjust the flow regulator by pulling out on the knob, turning it to the desired pressure, then pushing it back in to lock it in place.

CAUTION

To avoid damage to the processor, never shut off the rotameter. Only use the flow rate selector to turn the gas flow on or off.

- 7 Without closing the rotameter, adjust the rotameter valve to achieve the desired flow rate. It is recommended to start with a low flow rate, and then increase the rate as necessary.
- 8 Turn the flow rate selector to **Off**.
- 9 Add solvent or sample to each cartridge or well, as required by your method.

CAUTION

Solvent or sample spillage should be cleaned immediately to prevent damage to the processor.

- 10 Slide the collection platform under the manifold, until it reaches the stops.

CAUTION

Ensure the flow rate selector is set to **Off** whenever raising or lowering the manifold.

WARNING

When compressing or decompressing the cartridges, keep all body parts, hair, loose clothing, and extraneous objects away from the manifold.

- 11 Simultaneously press down on the two compression switches, until the manifold lowers completely. If the switches are released early, the manifold will rise. This is an intentional safety feature to keep your hands away from parts that move during the compression and decompression cycles. The compression and decompression speeds are preset and not adjustable.
- 12 Turn the flow rate selector to either **Low Flow** or **High Flow**, as required by your method.

Operation

- 13 Readjust the rotameter valve to achieve the desired liquid flow rate, adjusting as necessary throughout sample processing.
- 14 Once processing is complete, turn the flow rate selector to **Off**.
- 15 Simultaneously press up on the two compression switches until the manifold rises completely.
- 16 Pull the platform out from under the manifold, until it reaches the stops at the front of the processor.
- 17 Remove and separate the stack.
- 18 Repeat as required by your method.
- 19 Clean the silicone rubber sealing gasket with methanol.



5 Maintenance

Bleed off the Processor	30
Tubing Replacement	31
Sealing Gasket Replacement	32

Bleed off the Processor

After the gas supply has been shut off, the processor will remain pressurized until the pressure has been released. Agilent recommends bleeding off this excess pressure when the processor is not in use or if the processor will sit for an extended period. Situations where bleeding off the processor is necessary include, but are not limited to:

- The processor is being relocated or moved
- Maintenance is being performed
- Tubing is being disconnected/replaced
- The gas supply or filter is being changed

To bleed off the processor:

- 1 Turn off the gas supply.
- 2 If you are using a PPM-48, flip all four row switches down to open the row valves.
- 3 Turn the flow rate selector from **Off** to **High Flow**.
- 4 Wait until the pressure returns to 0 psi. Both pressure gauges should read "0", and there should be no audible hissing noise coming from the processor.
- 5 Turn the flow rate selector to **Off**.

Tubing Replacement

To replace the polyethylene tubing:

- 1 Bleed off the processor (see [“Bleed off the Processor”](#) on page 30).
- 2 Push in the outer ring of the push-to-connect fitting, while simultaneously pulling the tubing out of the fitting.

WARNING

When installing a new processor, or replacing tubing, only use the tubing provided in the installation kit supplied with your processor.

- 3 Push the new tubing from an installation kit (p/n 5191-4114) into the appropriate push-to-connect fittings (see [Figure 7](#) on page 24 and [Figure 8](#) on page 24). For more information on the installation kit, see [“Parts and Accessories”](#) on page 21.

Sealing Gasket Replacement

Replacement instructions are provided with each replacement sealing gasket. If the instructions provided differ from those listed here, follow the provided instructions. Agilent recommends replacing the sealing gasket every 6 to 12 months, depending on frequency of use, wear, and solvents used.

To replace the sealing gasket:

- 1 Bleed off the processor (see “Bleed off the Processor” on page 30).
- 2 Use the included 3/16 hex key to remove the two 1/4-20 screws fastening the manifold to the processor.
- 3 Lift the manifold from the standoffs, and place it upside down on the table.
- 4 Remove the old sealing gasket from the manifold.
- 5 Remove the old adhesive by wiping the surface areas with a lint-free cloth, dampened with either acetone or isopropanol.

CAUTION

Remove all adhesive residue from the manifold prior to installation of the new sealing gasket. Do not clog the holes of the manifold when removing old adhesive.

- 6 Remove the backing from the replacement sealing gasket.
- 7 For the PPM-96, insert two of the included screws into two opposite corners of the sealing gasket, and partially screw them into the threaded holes. Place the additional two screws in the remaining corners, and carefully adhere the replacement sealing gasket to the manifold, ensuring all ports are visible.

For the PPM-48, align the replacement seal with the manifold cartridge holes, and adhere it to the manifold.

- 8 On the PPM-96, once the sealing gasket is attached, remove the four screws.
- 9 Carefully set the manifold on the standoffs.
- 10 Attach the manifold to the processor using the 3/16 hex key and 1/4-20 screws.

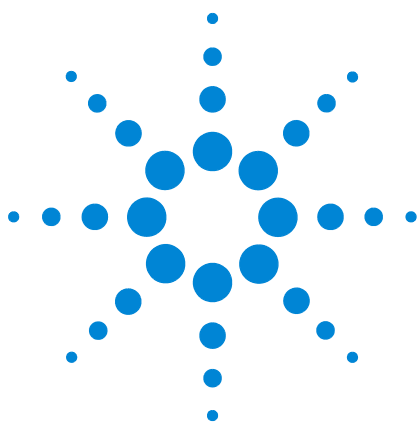

6 Reference Procedures

Using Your Agilent PPM-48 Processor 34

Using Your Agilent PPM-96 Processor 35

The following operating procedures can be printed and kept next to your processor for easy reference. For more details on operating your processor, see “[Sample Processing](#)” on page 26, or *A Technical Guide to Agilent Positive Pressure Manifold 48 and 96 Processors (5991-8151EN)*.

For important safety warnings that must be observed during processor operation, see “[Important Safety Warnings](#)” on page 8.



Using Your Agilent PPM-48 Processor

For important safety warnings that must be observed during processor operation, see “Important Safety Warnings” on page 8. For a more detailed operating procedure, see “Sample Processing” on page 26.

- 1 Assemble the cartridge stack and place it onto the platform.
- 2 Use the row switches to open the desired row valves.
- 3 Adjust the low flow regulator to achieve the desired pressure.
- 4 Add solvent/sample to the cartridges.

CAUTION

Solvent or sample spillage should be cleaned immediately to prevent damage to the processor.

- 5 Slide the platform back until it reaches the stops.

CAUTION

Ensure the flow rate selector is set to **Off** whenever raising or lowering the manifold.

WARNING

When compressing or decompressing the cartridges, keep all body parts, hair, loose clothing, and extraneous objects away from the manifold.

- 6 Lower the manifold.
- 7 Turn the flow rate selector from **Off** to **Low Flow**.

CAUTION

To avoid damage to the processor, never shut off the rotameter. Only use the flow rate selector to turn the gas flow on or off.

- 8 Adjust the rotameter to achieve the desired flow rate.
- 9 After elution, turn the flow rate selector to **Off**, and raise the manifold.
- 10 Slide the platform forward, and repeat steps 3-9 per protocol.
- 11 If a dry step is required: After elution of the solvent, turn the flow rate selector from **Low Flow** to **High Flow** and adjust the high flow regulator to achieve the desired pressure.
- 12 Collection step: Replace the waste rack with the appropriate collection rack and test tubes or autosampler vials. Use gravity or positive pressure (flow rate selector set to **Low Flow**), based on your specific protocol. Sample extracts may be diluted, dried down and reconstituted, or directly analyzed, based on your protocol.
- 13 Clean the silicone rubber sealing gasket with methanol.



Using Your Agilent PPM-96 Processor

For important safety warnings that must be observed during processor operation, see “Important Safety Warnings” on page 8. For a more detailed operating procedure, see “Sample Processing” on page 26.

- 1 Assemble the plate stack, and place it onto platform.
- 2 Adjust the low flow regulator to achieve the desired pressure.
- 3 Add solvent/sample to the wells.

CAUTION

Solvent or sample spillage should be cleaned immediately to prevent damage to the processor.

- 4 Slide the platform back until it reaches the stops.

CAUTION

Ensure the flow rate selector is set to **Off** whenever raising or lowering the manifold.

WARNING

When compressing or decompressing the cartridges, keep all body parts, hair, loose clothing, and extraneous objects away from the manifold.

- 5 Lower the manifold.
- 6 Turn the flow rate selector from **Off** to **Low Flow**.

CAUTION

To avoid damage to the processor, never shut off the rotameter. Only use the flow rate selector to turn the gas flow on or off.

- 7 Adjust the rotameter to achieve the desired flow rate.
- 8 After elution, turn the flow rate selector to **Off**, and raise the manifold.
- 9 Slide the platform forward, and repeat steps 3-8 per protocol.
- 10 If a dry step is required: After elution of the solvent, turn the flow rate selector from **Low Flow** to **High Flow**, and adjust the high flow regulator to achieve the desired pressure.
- 11 Collection step: Replace the single well waste plate with the appropriate collection plate. Use gravity or positive pressure (flow rate selector set to **Low Flow**), based on your specific protocol. Sample extracts may be diluted, dried down and reconstituted, or directly analyzed, based on your protocol.
- 12 Clean the silicone rubber sealing gasket with methanol.



Reference Procedures



Agilent Technologies

© Agilent Technologies, Inc.

Printed in USA, August 2017



G6695-90001